

### FEATURES

- Ultra-small board mount pressure sensor series with analog voltage and digital I2C output
- Pressure ranges from ultra-low pressure of 1.25 mbar (125 Pa) up to 2 bar
- Differential/relative, bidirectional differential, absolute and barometric sensor versions
- Piezoresistive sensor with high precision digital signal conditioning
- Calibrated and temperature compensated
- Total accuracy at room temperature: < 0.5 %FSO for pressure range 0 to 10 mbar
- Total error band (-25 ... 85 °C): < 1 %FSO for pressure range 0 to 10 mbar
- High long term stability
- Fast response time: < 2ms
- Analog output: 0.5 to 4.5 V ratiometric
- Digital output via I2C interface: 24 bit values for pressure and temperature
- Physical resolution A/D converter: 18 bit
- Resolution analog output: 16 bit
- Programmable I2C-address
- Short circuit protection of analog output against ground
- Extremely compact ceramic DIP-6 package (width: 0.43 inch)
- RoHS compliant

### TYPICAL APPLICATIONS

- Medical instrumentation
- HVAC (Heating, Ventilation, Air Conditioning)
- Building automation
- Gas and air flow measurement
- Safety-critical applications
- Air speed measurement
- Barometric altitude measurement
- Vacuum control

### GENERAL DESCRIPTION

The OEM pressure sensors in the AMS 6832 series are high-precision board mount sensors in an extremely compact DIP-6 package. The AMS 6832 feature two different outputs, an analog and a digital output. The analog 0.5 to 4.5 V output is ratiometric to the supply voltage and provides pressure measurement data only, while the I2C output provides pressure as well as temperature measurement data. Both outputs can be used simultaneously.

The sensors are extensively calibrated, linearized and temperature compensated in a wide temperature range of -25 ... 85 °C. As a result, high accuracy at room temperature and a very small total error band in the complete temperature range are achieved. Due to the membrane-based measurement principle, the sensors are gas-tight and the media connections are completely separated.

The sensors in the AMS 6832 series are available in various pressure ranges for all pressure types:

differential (relative) pressure sensors in ranges from 0 to 2.5 mbar up to 0 to 2 bar,

bidirectional differential pressure sensors (positive and negative pressure) from -1.25 to +1.25 mbar up to -1 to +1 bar,

absolute pressure sensors from 0 to 500 mbar up to 0 to 2 bar and

a barometric pressure sensor with a pressure range from 700 to 1200 mbar.

Additionally, customized pressure ranges, 3.3 V supply voltage types, different voltage output options or further modifications are available on request.

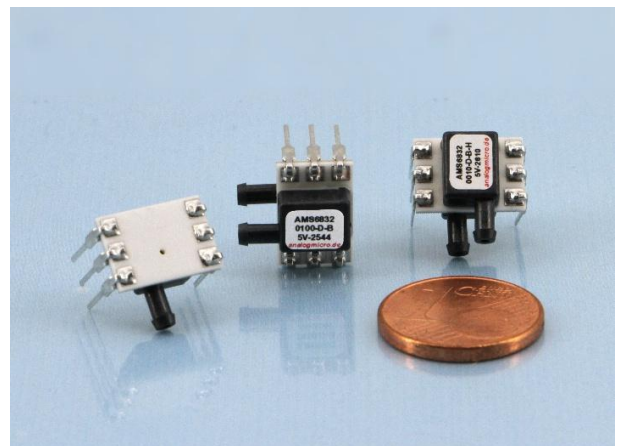

## PRESSURE RANGES

Sensor type (code)	Pressure type	Pressure range in mbar	Burst pressure <sup>1)</sup> in bar	Pressure range in Pa	Burst pressure in kPa
<b>Ultra-low pressure ranges</b>					
AMS 6832-0002-D-...	differential / relative <sup>2)</sup>	0 ... 2.5	> 0.2	0 ... 250	> 20
AMS 6832-0005-D-...	differential / relative	0 ... 5	> 0.2	0 ... 500	> 20
AMS 6832-0010-D-...	differential / relative	0 ... 10	> 0.2	0 ... 1000	> 20
AMS 6832-0012-D-...	differential / relative	0 ... 12.5	> 0.2	0 ... 1250	> 20
AMS 6832-0001-D-B-...	bidirectional differential	-1.25 ... 1.25	> 0.2	-125 ... 125	> 20
AMS 6832-0002-D-B-...	bidirectional differential	-2.5 ... +2.5	> 0.2	-250 ... +250	> 20
AMS 6832-0005-D-B-...	bidirectional differential	-5 ... +5	> 0.2	-500 ... +500	> 20
AMS 6832-0010-D-B-...	bidirectional differential	-10 ... +10	> 0.2	-1000 ... +1000	> 20
AMS 6832-0012-D-B-...	bidirectional differential	-12.5 ... +12.5	> 0.2	-1250 ... +1250	> 20
<b>Low pressure ranges</b>					
AMS 6832-0020-D-...	differential / relative	0 ... 20	> 0.4	0 ... 2000	> 40
AMS 6832-0035-D-...	differential / relative	0 ... 35	> 0.4	0 ... 3500	> 40
AMS 6832-0050-D-...	differential / relative	0 ... 50	> 1	0 ... 5000	> 100
AMS 6832-0100-D-...	differential / relative	0 ... 100	> 1	0 ... 10000	> 100
AMS 6832-0020-D-B-...	bidirectional differential	-20 ... +20	> 0.4	-2000 ... +2000	> 40
AMS 6832-0035-D-B-...	bidirectional differential	-35 ... +35	> 0.4	-3500 ... +3500	> 40
AMS 6832-0050-D-B-...	bidirectional differential	-50 ... +50	> 1	-5000 ... +5000	> 100
AMS 6832-0100-D-B-...	bidirectional differential	-100 ... +100	> 1	-10000 ... 10000	> 100
<b>Standard pressure ranges</b>					
AMS 6832-0200-D-...	differential / relative	0 ... 200	> 1.7	0 ... 20000	> 170
AMS 6832-0350-D-...	differential / relative	0 ... 350	> 5	0 ... 35000	> 500
AMS 6832-0500-D-...	differential / relative	0 ... 500	> 5	0 ... 50000	> 500
AMS 6832-1000-D-...	differential / relative	0 ... 1000	> 5	0 ... 100000	> 500
AMS 6832-2000-D-...	differential / relative	0 ... 2000	> 5	0 ... 100000	> 500
AMS 6832-0200-D-B-...	bidirectional differential	-200 ... +200	> 1.7	-20000 ... +20000	> 170
AMS 6832-0350-D-B-...	bidirectional differential	-350 ... +350	> 5	-35000 ... +35000	> 500
AMS 6832-0500-D-B-...	bidirectional differential	-500 ... +500	> 5	-50000 ... +50000	> 500
AMS 6832-1000-D-B-...	bidirectional differential	-1000 ... +1000	> 5	-100000 ... 100000	> 500
AMS 6832-0500-A-...	absolute	0 ... 500	> 5	0 ... 50000	> 500
AMS 6832-1000-A-...	absolute	0 ... 1000	> 5	0 ... 100000	> 500
AMS 6832-1500-A-...	absolute	0 ... 1500	> 5	0 ... 150000	> 500
AMS 6832-2000-A-...	absolute	0 ... 2000	> 5	0 ... 200000	> 500
AMS 6832-1200-B-...	absolute (barometric)	700 ... 1200	> 5	0 ... 200000	> 500

**Table 1: AMS 6832 standard pressure ranges (other pressure ranges on request)**

**Notes:**

- 1) Burst pressure is defined as the maximum pressure which may be applied to one pressure port relative to the other port (or while only one pressure port is connected) without causing leaks in the sensor.
- 2) Relative pressure is the difference between applied pressure and atmospheric pressure. It is often also called gage or gauge pressure.

## MAXIMUM RATINGS

Parameter	Minimum	Typical	Maximum	Units
Maximum supply voltage: $V_{S,max}$			6.5	V
Operating temperature: $T_{op}$	-25		85	°C
Storage temperature: $T_{amb}$	-40		125	°C
Common mode pressure: $p_{CM}^{(1)}$			8	bar

**Table 2: Maximum ratings**

**Note:**

- 1) Common mode pressure is defined as the maximum pressure, which can be applied simultaneously on both pressure ports without causing damages, while no differential pressure is applied.

## SPECIFICATIONS

All parameters apply  $V_S = 5.0$  V,  $p_{CM} = 0$  mbar and  $T_{op} = 25$  °C, unless otherwise stated.

Parameter	Minimum	Typical	Maximum	Units
<b>Analog output signal (pressure)<sup>1)</sup></b>				
@ specified minimum pressure (see "pressure range") <sup>2)</sup>		0.5		V
@ specified maximum pressure (see "pressure range") <sup>2)</sup>		4.5		V
Full span output (FSO) <sup>3)</sup>		4.0		V
without pressure (bidirectional differential)		2.5		V
<b>Digital output signal (pressure)<sup>4)</sup></b>				
@ specified minimum pressure (see "pressure range") <sup>2)</sup>		$0.1 \cdot 2^{24}$		counts
@ specified maximum pressure (see "pressure range") <sup>2)</sup>		$0.9 \cdot 2^{24}$		counts
Full span output (FSO) <sup>3)</sup>		$0.8 \cdot 2^{24}$		counts
without pressure (bidirectional differential)		$0.5 \cdot 2^{24}$		counts
<b>Digital output signal (temperature)<sup>5)</sup></b>				
@ minimum temperature $T = -25$ °C		$0.09 \cdot 2^{24}$		counts
@ maximum temperature $T = 85$ °C		$0.75 \cdot 2^{24}$		counts
<b>Total accuracy<sup>6) 7)</sup> (pressure measurement) @ <math>T = 25</math> °C</b>				
For pressure ranges: $\pm 1.25$ mbar, 0 ... 2.5 mbar			$\pm 1.5$	%FSO
Pressure ranges: $\pm 2.5$ mbar, 0 ... 5 mbar			$\pm 1.0$	%FSO
Pressure ranges: $\pm 5$ mbar, 0 ... 10mbar and $\pm 10$ mbar			$\pm 0.5$	%FSO
Pressure ranges: 0 ... 20 mbar, $\pm 20$ mbar and above			$\pm 0.35$	%FSO
<b>TEB/Overall error<sup>8) 7)</sup> (pressure meas.) @ <math>T = -25 \dots 85</math> °C</b>				
Pressure ranges: $\pm 1.25$ mbar, 0 ... 2.5 mbar			$\pm 2.0$	%FSO
Pressure ranges: $\pm 2.5$ mbar, 0 ... 5 mbar			$\pm 1.5$	%FSO
Pressure ranges: $\pm 5$ mbar, 0 ... 10mbar and $\pm 10$ mbar			$\pm 1.0$	%FSO
Pressure ranges: 0 ... 20 mbar, $\pm 20$ mbar and above			$\pm 0.5$	%FSO
<b>Total error for temperature measurement</b>				
All types of AMS 6832 $T = -25 \dots 85$ °C			$\pm 1.0$	%FSO
Long term stability			< 0.5	%FSO/a
Supply voltage ( $V_S$ )	4.5	5.0	5.5	V

Parameter	Minimum	Typical	Maximum	Units
Ratiometricity error (@ $V_S = 4.75 \dots 5.25 \text{ V}$ )			0.15	%FSO
Resolution A/D converter (physical)		18		Bits
Resolution digital pressure signal	16			bits
Minimum resolution analog voltage output		0.0015		%FSO
Resolution temperature signal		13		bits
Maximum output current <sup>9)</sup>		10		mA
Current consumption ( $R_L = 1 \text{ M}\Omega$ )			3.5	mA
Output update rate		500		Hz
Start-up time to interface communication		2		ms
Start-up time analog output ( $V_S$ ramp up to output signal)		5		ms
Compensated temperature range	-25		85	°C
External Capacitance (between $V_S$ and GND) <sup>10)</sup>	0	100		nF
<b>I2C-interface</b>				
Input high level	80		100	% $V_S$
Input low level	0		20	% $V_S$
Output low level	0		20	% $V_S$
Load capacitance @ SDA		100	400	pF
Clock frequency SCL	0.1		3.4	MHz
Pull-up resistor	1	10		k $\Omega$
Pressure cycles (0 to 120 % full scale pressure)	>10 <sup>6</sup>			cycles
Lifetime / MTTF	>10			years
Package	DIP-6 (width: 0.43 inch)			
Weight		1		g
Dimensions without tubes and pins ( $L \times W \times H$ )	11 x 7.6 x 7.2			mm
Media compatibility	See "Specification notes" <sup>11), 12)</sup>			

**Table 3: Specifications**

## SPECIFICATION NOTES

- 1) The analog output signal (pressure measurement only) is ratiometric to the supply voltage.
- 2) The pressure ranges with specified minimum and maximum pressure are listed in *Table 1*.
- 3) The Full Span Output (FSO) is the algebraic difference between the output signal at the specified maximum pressure and the output signal at the specified minimum pressure.
- 4) The digital output pressure signal is not ratiometric to the supply voltage.
- 5) The digital output temperature signal is not ratiometric to the supply voltage. The temperature value is measured at the sensor's piezoresistive sensing element and is the sensor temperature (including self-heating).
- 6) Total accuracy is defined as the maximum deviation of the measurement value from the ideal characteristic curve at room temperature (RT) in %FSO including the adjustment errors (offset and span), nonlinearity, pressure hysteresis and repeatability. Nonlinearity is the measured deviation from the best fit straight line (BFSL) across the entire pressure range. Pressure hysteresis is the maximum deviation of the output value at any pressure within the specified range when the pressure is cycled to and from the minimum or maximum rated pressure. Repeatability is the maximum deviation of the output value at any pressure within the specified range after 10 pressure cycles.
- 7) The digital and analog output values may not be equal by up to 0.2 %FSO, nonetheless total accuracy/TEB specifications are always valid for each output.
- 8) The TEB (total error band or overall error) is defined as the maximum deviation of the measurement value from the ideal characteristic curve in %FSO across the entire temperature range (-25 ... 85 °C).
- 9) The analog output is protected against short circuit to ground (GND).

- 10) An external capacitor is recommended.
- 11) Media compatibility of pressure port 1 (for a description of port 1 see Figure 5): fluids and gases non-corrosive to silicon, Pyrex, RTV silicone rubber, epoxy and LCP.
- 12) Media compatibility of pressure port 2 (for a description of port 2 see Figure 5): clean, dry gases, non-corrosive to LCP, silicon, RTV silicone rubber, epoxy, gold (alkaline or acidic liquids can destroy the sensor).

## FUNCTIONAL DESCRIPTION

The pressure sensors in the AMS 6832 series combine a high quality piezoresistive silicon sensing element with a modern mixed-signal CMOS ASIC for signal-conditioning in a ceramic hybrid package. This combination enables a low total error band, excellent temperature behavior and long-term stability. AMS 6832's functional principle is explained using Figure 1.

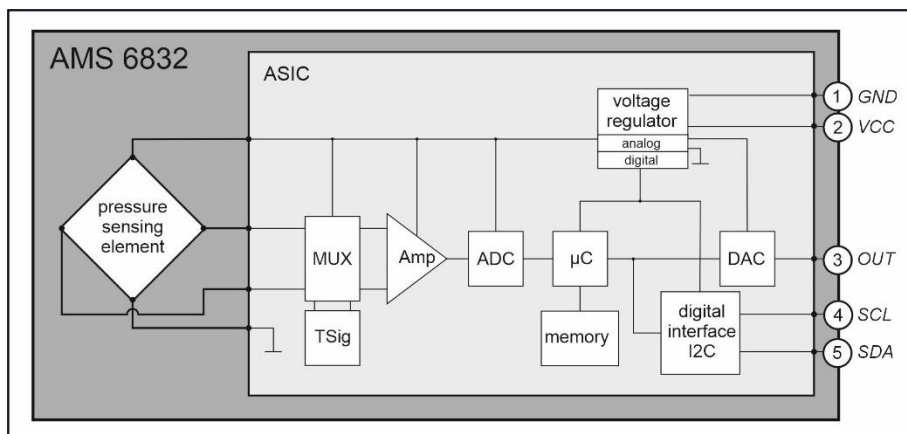

**Figure 1: Functional principle**

The physical pressure applied to AMS 6832's pressure ports is converted into a differential voltage signal at the sensor's pressure sensing element. This pressure related differential voltage is signal conditioned in the mixed signal ASIC to realize a standardized voltage and a digital I2C-output.

In detail, the signal conditioning is realized in the following way:

At first, the pressure related differential voltage is transmitted through a multiplexer (MUX) and an amplifier (Amp) to the A/D converter block (ADC), where it is converted into a digital value with 18 bit physical resolution. This digitized pressure raw value is then mathematically processed by the ASIC's integrated microcontroller unit ( $\mu$ C) to obtain a calibrated and temperature compensated output signal. For this purpose, the  $\mu$ C uses a correction algorithm and individual correction coefficients which are stored in the ASIC's memory during the factory calibration process. This permits a sensor-specific calibration and correction (i.e. linearization and temperature compensation) of the digitized pressure signal. The temperature signal, which is required for the temperature compensation of the digitized pressure raw value, is generated in the ASIC's temperature reference block (TSig) and transmitted via the multiplexer and the amplifier to the ADC, where it is digitized too.

The ASIC's microcontroller unit ( $\mu$ C) executes a cyclic program, which continuously calculates the current standardized and corrected digital pressure value based on the latest digitized pressure and temperature measurement values and the stored correction coefficients. Additionally, a standardized digital value of the current temperature is calculated.

The standardized digital pressure and temperature measurement values are written to the ASIC's output registers and are continuously updated (typically every 2 ms). These digital measurement data, which are non ratiometric to the supply voltage, can be read out as 24 bit values via I2C commands using AMS 6832's digital interface at PIN 4 (SDA) and PIN5 (SCL).

The pressure related standardized analog output voltage at the sensor's PIN3 (OUT) is generated by the 16 bit D/A converter block (DAC). The DAC converts the present digital pressure measurement value into an analog voltage, which is ratiometric to the supply voltage.

**INITIAL OPERATION**

**Electrical Connection**

The electrical connection of AMS 6832 sensors is typically established by soldering them directly on a printed circuit board or by mounting them on a suitable socket.<sup>1)</sup>

The basic electronic circuit for an AMS 6832 sensor with analog and digital output in use is shown in *Figure 2*. To use the analog ratiometric voltage output only, it is sufficient to connect PIN1 (GND), PIN2 (VCC) and PIN3 (OUT). To read the digital output only, it is enough to connect PIN1 (GND), PIN2 (VCC) and the I2C-bus lines to PIN4 (SCL) and PIN5 (SDA).

**Important:** SDA and SCL line have to be connected to the positive supply voltage (pin VCC) via a pull-up resistor. Please add pull-up resistors (10 kΩ are recommended) to your bus line if they are not integrated in the I2C-master.

An external capacitor, e.g. 100 nF, is recommended between VCC and GND to reduce noise and stabilize the supply voltage.

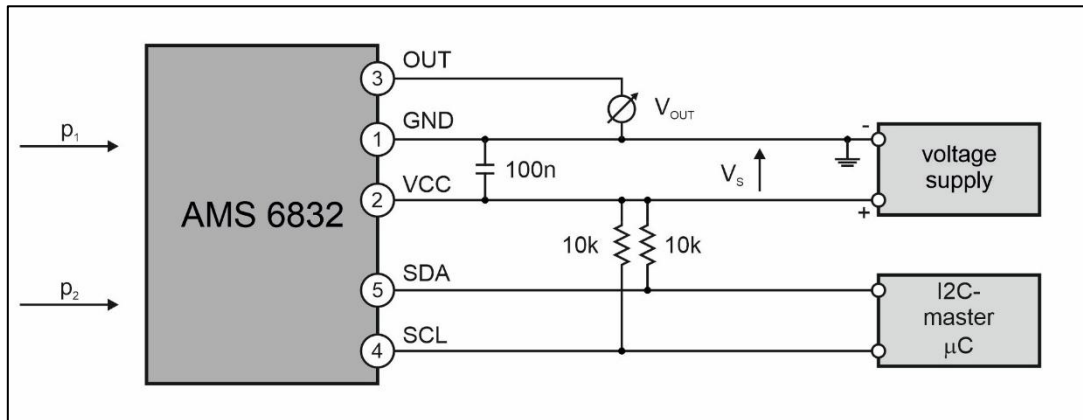

**Figure 2: Principle electric circuitry**

**Pressure Connection**

The pressure connection is established using suitable tubing<sup>2)</sup> attached to AMS 6832's barbed pressure ports. Depending on the sensor type and the type of measuring pressure, one or two of the pressure ports have to be connected to the measuring medium / volume, as described in the table below:

Sensor type	Pressure type to measure	Port 1	Port 2	Requirement
AMS 6832-xxxx-D	differential ( $\Delta p = p_1 - p_2$ )	connected to $p_1$	connected to $p_2$	$p_1 \geq p_2$
	positive gage	connected to $p_1$	open	$p_1 \geq p_{\text{ambient}}$
	negative gage (vacuum)	open	connected to $p_2$	$p_2 \leq p_{\text{ambient}}$
AMS 6832-xxxx-D-B	bidirectional differential ( $\pm \Delta p$ )	connected to $p_1$	connected to $p_2$	$p_1 \geq p_2$ or $p_1 \leq p_2$
AMS 6836-xxxx-A	absolute	n.a. (open)	connected to $p_2$	$p_2 = \text{meas. pressure}$
AMS 6836-xxxx-B	absolute (barometric)	n.a. (open)	connected to $p_2$	$p_2 = \text{meas. pressure}$

with  $p_1$  = pressure connected to pressure port 1 and  $p_2$  = pressure connected to pressure port 2. For port declaration see *Figure 5*.

The media compatibility of pressure ports 1 and 2 can be found in "Specification notes", 10) and 11).

**Notes:**

- 1) ESD precautions are necessary, it is essential to ground machines and personnel properly during assembly and handling of the device.
- 2) For horizontal pressure port configuration Analog Microelectronics GmbH recommends silicone tubing with inner diameter  $\varnothing = 1.6$  mm, outer diameter  $\varnothing = 3.2$  mm.

## I2C INTERFACE

AMS 6832 pressure sensors have a digital I2C-interface. When connected to a bidirectional I2C-bus, the current digital output values for pressure and temperature can be read from AMS 6832's output register.

The I2C-bus requires only two bus lines: a serial data line (SDA) and a serial clock line (SCL). SDA and SCL are bidirectional lines connected to the positive supply voltage via pull-up resistors (see *Figure 2*).

Communication via the I2C-bus follows a simple master-slave principle. The data transfer is always initialized by the master (e.g., a microcontroller), which sends a data request command to the sensor AMS 6832. The sensor – which always operates as slave – responds then.

AMS 6832's communication protocol follows a standard I2C communication protocol (shown in *Figure 3*).

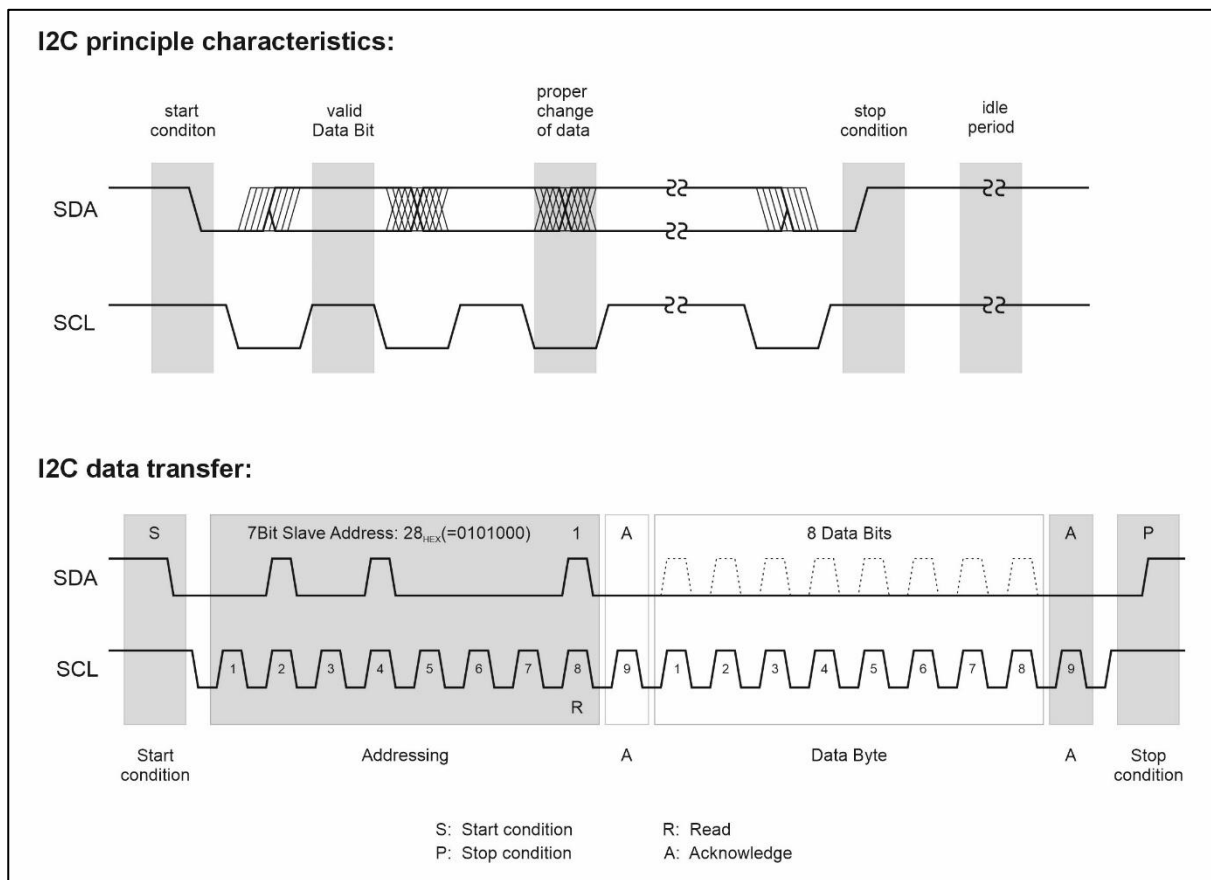

**Figure 3: Standard I2C protocol**

The typical I2C communication phases on the two bus lines are as follows:

### Idle period (bus is free)

When the bus is free, both I2C-bus lines (SDA and SCL) are pulled up to supply voltage level.

### Start S (start condition)

Prior to any data transfer on the bus, a start condition has to be generated. The start condition is always sent by the I2C master. The start condition is defined as a transition from high-level voltage to low-level voltage on the SDA line, while the SCL line is still on high-level voltage.

### Stop P (stop condition)

The stop condition is always generated by the I2C master after a data transfer has been completed. The stop condition is defined as a transition from low-level to high-level voltage on the SDA line while the SCL line is still on high-level voltage. The I2C communication with AMS 6832 is always terminated by a stop condition.

### Valid data

Data is transmitted in bytes (1 byte = 8 bit), starting with the most significant bit. Each data bit is transmitted with the related clock pulse generated by the I2C master. The transmitted bits are only valid if, following a start condition, the level on the SDA line is constant as long as the SCL line is on high-level voltage. Changes to the SDA level must be made while the SCL line is on low-level voltage.

### Acknowledge A / Not Acknowledge N

After a byte has been transmitted, the respective receiver (I2C master or sensor) has to send an acknowledge (additional acknowledge bit) confirming the correct receipt of the data. For this purpose, the I2C master generates an extra acknowledge-related clock pulse. The receiver sends the acknowledge bit by pulling down the SDA line to low-level voltage during the additional clock pulse. If the SDA line remains at high-level voltage during the acknowledge-related clock pulse, it is interpreted as not acknowledge.

### Addressing the slave (I2C-address AMS 6832)

After the start condition, the I2C master sends an addressing byte to initiate the communication with a specific sensor. The addressing byte contains the individual 7-bit address of the selected slave (sensor AMS 6832) and additionally a data direction bit (R/W). A "0" for the R/W bit indicates a transmission from the master to the slave (W: write; the master wants to transmit data to the selected slave), a "1" indicates a data request (R: read; the master requests data from the slave).

The pressure sensors in the AMS 6832 series have a factory-programmed 7-bit address of 0x28<sub>Hex</sub> (0101000<sub>bin</sub>), which is stored in the sensor's memory. On request, each AMS 6832 can be ordered with an individual 7-bit address programmed at the factory.

In general, 7-bit addressing allows 128 different addresses. If more than one slave is connected to the same I2C bus, each slave requires an individual I2C address. Since AMS 6832 uses the addresses 0x04<sub>Hex</sub> to 0x07<sub>Hex</sub> internally, they are not available as I2C address. Thus, 124 different addresses for AMS 6832 remain for the user's purpose.

Using the AMS 6832 USB Starter Kit, the factory programmed I2C address can be changed by the user himself.

### Notes:

There are three differences between AMS 6832's communication protocol and the original I2C communication protocol:

- 1) A stop condition directly after a start condition without clock pulses in between is not allowed. This creates a communication error for the next communication.
- 2) A second start condition (restart) during data transmission when SCL is still high is not allowed.
- 3) Between the start condition and the first rising SCL edge, a falling SDA edge is not allowed.

## MEASUREMENT DATA READOUT VIA I2C

The digital output measurement values for pressure and temperature can be read from AMS 6832's output register via the I2C-interface with 24-bit length. The AMS 6832 operate in update mode and automatically refresh the pressure and temperature measurement values with a typical update rate of 2 ms.

The I2C communication for the data read out is illustrated in *Figure 4*.

To initiate the data readout, the I2C master (controller, typically a microcontroller) generates a start condition and sends the addressing byte containing the 7-bit I2C address of the selected sensor (AMS 6832's standard address is 0x28<sub>Hex</sub>) followed by the data direction bit (R = '1'). The sensor answers with an acknowledge bit during the acknowledge-related clock pulse and starts to send the data stored in its output register to the controller.

For a complete pressure and temperature measurement, 7 bytes are sent. The first byte contains the sensor's status (for interpretation see section DATA INTERPRETATION), the next three bytes contain the sensor's current 24-bit digital pressure measurement value, and the last three bytes the 24-bit digital temperature measurement value. The measurement data always start with the most significant byte (MSB) and each byte begins with the most significant bit. On each transferred data byte, the controller sends an acknowledge bit, which confirms the correct receipt of the data. After the seventh byte, the controller stops the readout by sending a not-acknowledge bit and a stop condition.

If less than the full seven data bytes are required, the controller can stop the data transfer after every complete byte by sending a not-acknowledge bit and a stop condition. For example, this allows to read the status byte only (stop after 1 byte) or to stop the readout after the pressure measurement data (stop after four bytes).

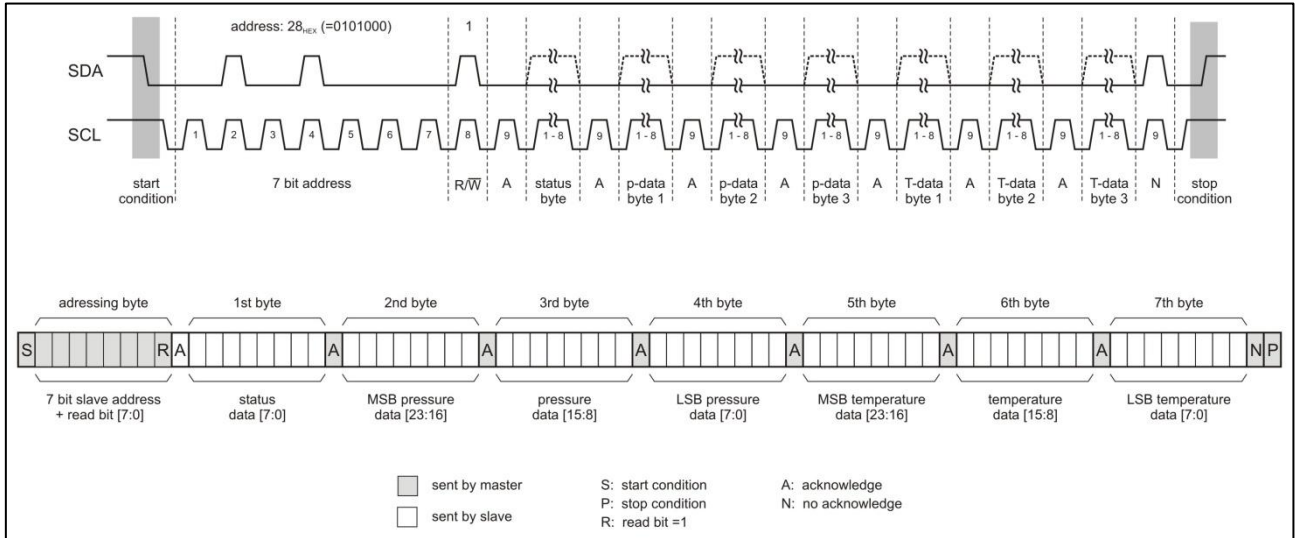

**Figure 4:** I2C data readout of the full measurement data of 7 bytes

## DATA INTERPRETATION

### Status byte

The status byte contains essential information about the AMS 6832’s state. It is always sent by the sensor as the first data byte in a data read process and contains the following information, also shown in *Table 4*:

Status bit [7:3]: always [0 1 1 0 1]

Status bit 2 - memory check: During power-up the AMS 6832 performs a memory check. If the check is completed without errors, the bit is “0”. If it is “1”, it indicates an uncontrolled change of a memory register and the sensor might not work properly.

Status bit 1: always [0]

Status bit 0 - overflow indication: This bit indicates a signal overflow. It is “0”, if the sensor data is valid. If it is “1”, the applied pressure exceeds the sensor’s pressure range.

status bit	7	6	5	4	3	2	1	0
default	0	1	1	0	1	0	0	0
meaning	-	-	-	-	-	0, if memory check was passed	-	0, if sensor is not in overflow

**Table 4:** AMS 6832’s status byte

### Calculating the measured values for digital pressure and temperature in physical units

The digital pressure value is given by the bytes 2, 3 and 4, with byte 2 being the most significant byte and byte 4 the least significant one. In the same way, the temperature value consists of the bytes 5, 6 and 7. In order to generate the desired information on pressure and temperature, the digital output values have to be converted into physical units.

The current pressure in the desired physical unit (e.g. mbar) is calculated from the digital pressure value using the following equations:

$$p = \frac{Digoutp(p) - Digoutp_{min}}{Sensp} + p_{min} \quad \text{with} \quad Sensp = \frac{Digoutp_{max} - Digoutp_{min}}{P_{max} - P_{min}} \quad (1)$$

wherein

$p$  is the current pressure in the desired physical unit (e.g. mbar, Pa),

$p_{min}$  and  $p_{max}$  are the specified minimum and maximum pressure values in the desired physical unit (e.g. in mbar) depending on the sensor's specific pressure range (see Table 1)

$Digoutp(p)$  is the current digital 24-bit pressure measurement value in counts,

$Digoutp_{min}$  is the digital pressure measurement value at the minimum specified pressure in counts,

$Digoutp_{max}$  is the digital pressure measurement value at the maximum specified pressure in counts,

$Sensp$  is the sensitivity of the pressure sensor (e.g. in counts/mbar, counts/Pa).

The current sensor temperature in °C is calculated from the digital temperature output value using the following equation:

$$T = \frac{(DigoutT(T) \cdot 165)}{2^{24}} - 40 \quad (2)$$

Therein  $T$  is the current sensor temperature in °C and  $DigoutT(T)$  is the current 24 bit digital temperature output value in counts.

### Example

At the digital output of an AMS 6832-0005-D-B (-5 ... 5 mbar bidirectional differential sensor) the following data bytes 1 ... 7 are read:

Byte 1: 0x48<sub>Hex</sub>    Byte 2: 0xB9<sub>Hex</sub>    Byte 3: 0x12<sub>Hex</sub>    Byte 4: 0xD4<sub>Hex</sub>    Byte 5: 0x62<sub>Hex</sub>    Byte 6: 0xAA<sub>Hex</sub>  
 Byte 7: 0x33<sub>Hex</sub>

Byte 1 is the status byte and not necessary for the calculation.

Taking bytes 2, 3 and 4 the current 24-bit digital pressure value is:

$$Digoutp(p) = B9\ 12\ D4_{Hex} \text{ counts} = 12128980_{Dec} \text{ counts}$$

and with byte 5, 6 and 7 the digital temperature value is:

$$DigoutT(T) = 62\ AA\ 33_{Hex} \text{ counts} = 6466099_{Dec} \text{ counts}$$

For AMS 6832-0005-D-B the following values are specified:

$$p_{min} = -5 \text{ mbar}, \quad p_{max} = 5 \text{ mbar} \text{ and } Digoutp_{min} = 0.1 \cdot 2^{24}, \quad Digoutp_{max} = 0.9 \cdot 2^{24}$$

Using these values and equation (1) the current pressure in mbar can be calculated:

$$p = \frac{(12128980 - 0.1 \cdot 2^{24}) \text{ counts}}{(0.8 \cdot 2^{24} / 10) \text{ counts / mbar}} + (-5) \text{ mbar} = 2.787 \text{ mbar}$$

Using equation (2), the current sensor temperature in °C is calculated as:

$$T = \frac{(6466099 \cdot 165) \text{ counts} \cdot ^\circ\text{C}}{2^{24} \text{ counts}} - 40 \text{ } ^\circ\text{C} = 23.6 \text{ } ^\circ\text{C}$$

### DIMENSIONS AND PINOUT

AMS 6832 pressure sensors come in an ultra-miniaturized dual-in-line package (DIP-06) for assembly on printed circuit boards (PCB).

The pinout and the dimensions of AMS 6832's ceramic hybrid package with horizontal barbed pressure ports is illustrated in *Figure 5*.

**Important:** Pin 6 is reserved for use during the manufacturing process and must remain electrically unconnected.

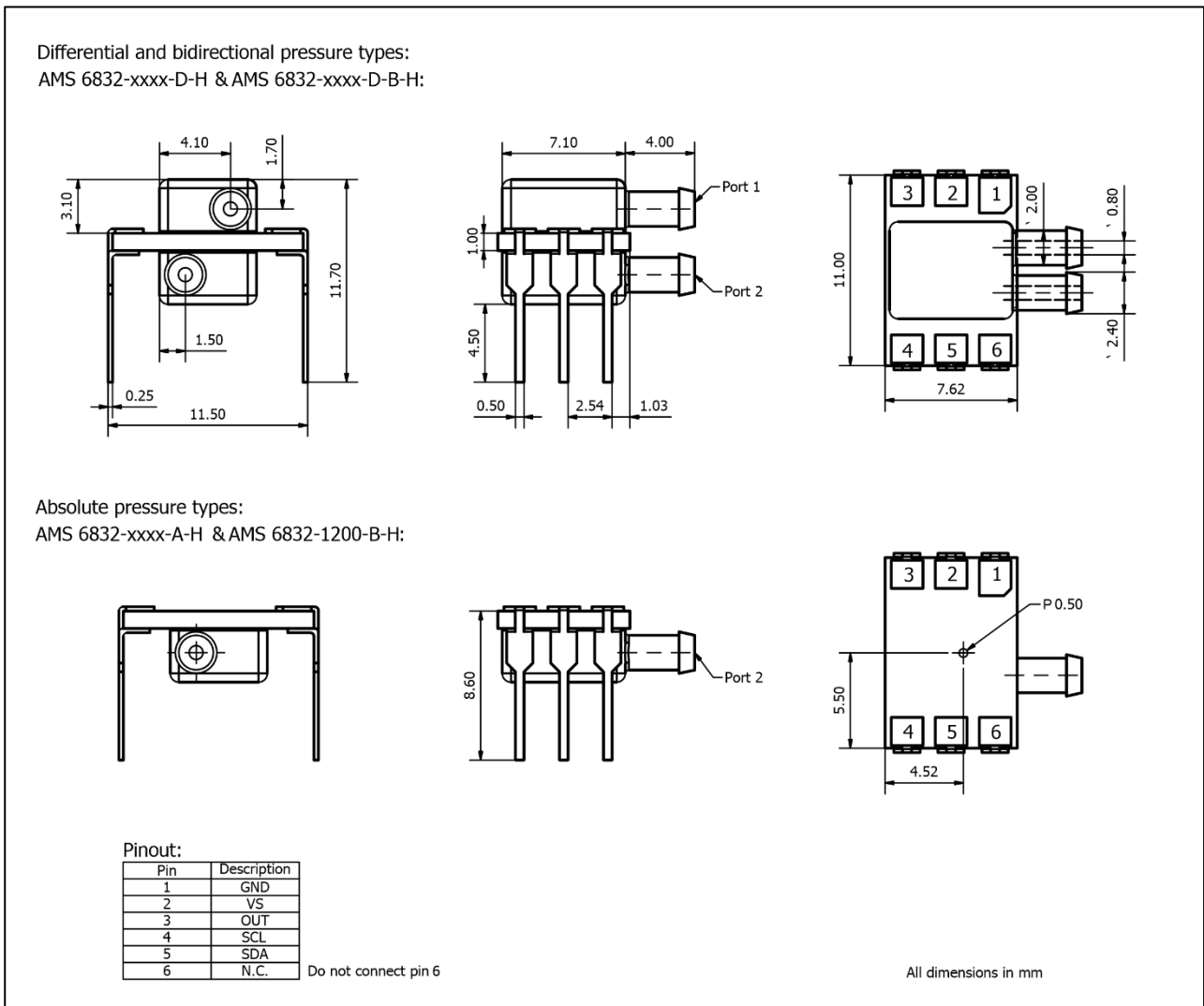

**Figure 5: Dimensions and pinout of AMS 6832's standard package**

**INFORMATION FOR ORDERING**

**ORDERING CODE:**

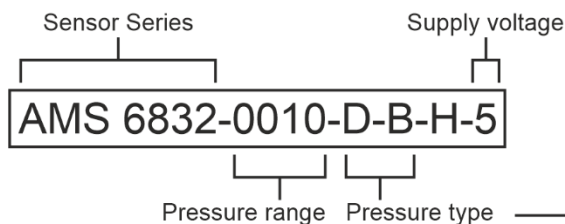

Pressure range code	mbar	Pa	psi	inH <sub>2</sub> O
0001	1.25	125	0.018	0.501
0002	2.5	250	0.036	1.003
0005	5	500	0.073	2.007
0010	10	1000	0.145	4.014
0012	12.5	1250	0.181	5.018
0020	20	2000	0.290	8.029
0035	35	3500	0.507	14.051
0050	50	5000	0.725	20.073
0100	100	10 000	1.450	40.146
0200	200	20 000	2.901	80.295
0350	350	35 000	5.076	140.516
0500	500	50 000	7.252	200.737
1000	1000	100 000	14.503	401.474
1500	1500	150 000	21.756	600.211
2000	2000	200 000	29.007	802.948
1200	1200	120 000	17.405	481.769

Code	Pressure type	Available pressure ranges
D	Differential / relative (gage)	0 ... 2.5 to 0 ... 2000 mbar
D-B	Bidirectional differential	-1.25 ... +1.25 to -1000 ... 1000 mbar
A	Absolute	0 ... 500 mbar(a) to 0 ... 2 bar(a)
B	Barometric (absolute)	700 ... 1200 mbar(a)

**Analog Microelectronics GmbH**  
 An der Fahrt 13  
 55124 Mainz  
 Germany



your distributor  
 AMSYS GmbH & Co.KG  
 An der Fahrt 4, 55124 Mainz, Germany  
 Tel. +49 (0) 6131 469 875 0  
 info@amsys.de | www.amsys.de

**Phone: +49 (0) 6131/91 073-0**  
**Fax: +49 (0) 6131/91 073-30**  
**Internet: www.analog-micro.com**  
**E-Mail: info@analogmicro.de**

Analog Microelectronics GmbH reserves the right to amend any dimensions, technical data or other information contained herein without prior notification.