

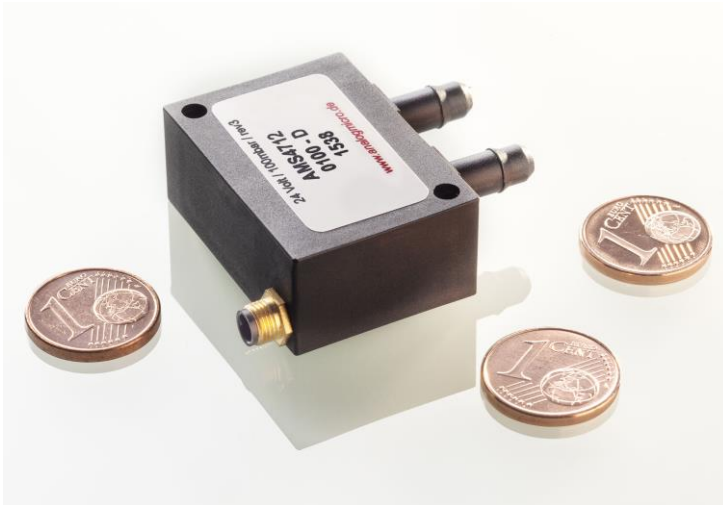

# AMS 4712 – two-wire current loop with the example of a 4 - 20 mA pressure transmitter



**Figure 1:** pressure transmitter\* AMS 4712 with a two-wire current output

Although digital transmission has become standard in electronic devices, for example with I<sup>2</sup>C and SPI protocols, analog signal transmission systems are still used in large numbers, such as to cover long distances and in environments subject to interference. Current signals in particular are useful in means of transmitting information.

As some young engineers are not familiar with this circuit application, the functions of current signal transmission shall be described herein, taking the AMS 4712 pressure transmitter\* [1] as an example.

## Two-wire signal transmission

When transmitting signals across larger distances or in environments prone to electromagnetic interference (EMI), for many years normed current signals have been used. In practical industrial use we differentiate between two- and three-wire transmission. As the two-wire variants, which are also described as current loops, enjoy greater significance, the following article shall concentrate on this proven, inexpensive, 4 – 20 mA circuit technology.

The simplest instance of a two-wire current loop comprises an adjustable current source and a receiver in the form of a terminating resistor where the useful signal can be tapped.

In the given sensor application (Figure 2) it is assumed that the transmitter can generate the required signal current of  $I_{OUT} = 4 - 20 \text{ mA}$  depending on a physical measurement. Resistor  $R_L$  acts as a receiver where voltage drop  $V_A$  or, in series, current  $I_{OUT}$  can be measured directly.

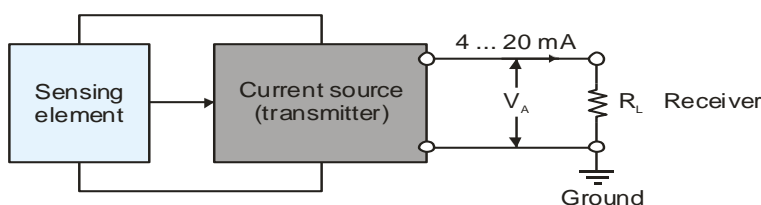

**Figure 2:** Schematic diagram of a sensor with a 4...20 mA output

\*Transmitter is understood to mean a sensor which is linearized, is calibrated to standard values, compensates within a given temperature range and is mounted in a ready-to-mount package.

AMSYS GmbH & Co.KG  
An der Fahrt 4  
55124 Mainz  
GERMANY

phone: +49 (0) 6131 469 875 0  
fax: +49 (0) 6131 469 875 66  
email: [info@amsys-sensor.com](mailto:info@amsys-sensor.com)  
internet: [www.amsys-sensor.com](http://www.amsys-sensor.com)  
status: February 2016



# AMS 4712 – two-wire current loop with the example of a 4 - 20 mA pressure transmitter

## Pressure transmitter

Stationary transmitters are electrical systems which can be supplied with power externally. They generally consist of a sensing element, amplifier circuitry, a circuit for signal conditioning with an ADC, EEPROM, processor and an output stage. The analog AMS 4712 also has a DA converter. All electrical functional units are realized here on a single ASIC (Figure 3).

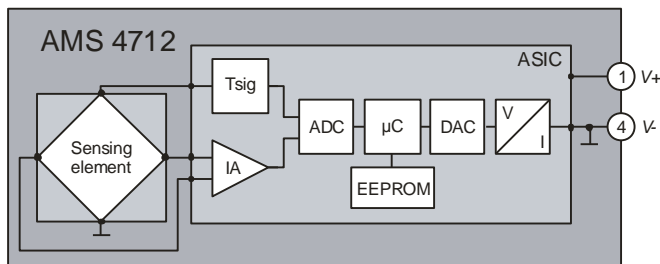

Figure 3: Block diagram of transmitter AMS 4712

As all of the pressure sensing elements generate separate output values, the electronics on AMS 4712 must be able to individually set the setpoint and full scale signal. In addition to this calibration, the temperature effect on the signal should also be corrected. This is done with the help of the integrated temperature sensor in the digital section of the evaluation circuitry.

The calibration procedures (calibration and temperature compensation) are performed during manufacture of AMS 4712 pressure transmitters by individual electronic calibration under the application of pressure and temperature.

As most sensing elements generate a voltage between the setpoint and an end value, in the case of AMS 4712 the output stage must be a voltage-controlled current controller which together with the power supply is able to generate a minimum current of 4 mA (setpoint = zero signal of the measurement sensor) and a maximum current of 20 mA (full scale or FS = end value of the measurement sensor).

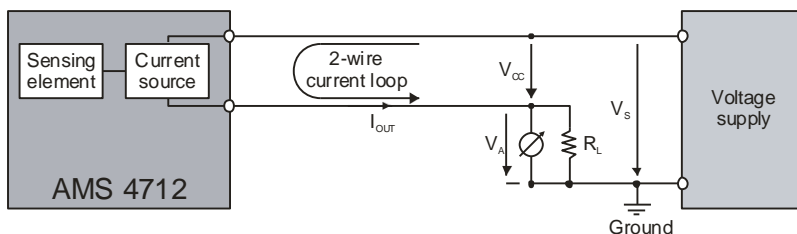

Figure 4: Practical application of the current loop circuit

As shown in Figure 4, for two-wire operation of the AMS 4712 pressure transmitter the user only has to connect up the voltage supply and a load resistor  $R_L$ . Here, the power supply must provide a current of  $\geq 20$  mA.



# AMS 4712 – two-wire current loop with the example of a 4 - 20 mA pressure transmitter

## Load resistor dimensioning

The only component the AMS 4712 user has to adapt to suit the specific situation is load resistor  $R_L$ .

The following calculation applies when dimensioning the component (*Figure 4*):

$$V_S = V_{CC} + V_A = V_{CC} + I_{OUT} \cdot R_L \quad [1]$$

The minimum value of  $V_{CC}$  is predefined by the minimum voltage for the electronic circuits (ASIC and sensing element) inside the sensor. Minimum supply voltage  $V_S$  thus amounts to:

$$V_S \geq V_{CCmin} + I_{OUTmax} R_L \quad [2]$$

$$R_L \leq (V_S - V_{CCmin}) / I_{OUTmax} \quad [3]$$

From equation [3] the area of the load resistor dependent on the supply voltage is accrued as shown in *Figure 5*.

In the case of AMS 4712\* the following applies:  $V_{CCmin} = 8 \text{ V}$ ,  $I_{OUTmax} = 20 \text{ mA}$  and  $R_{Lmax} = f(V_S)$

It must also be observed that with long cables inner cable resistance  $R_K$  must also be included in equation [3] as an additive quantity.

$$V_S \geq V_{CCmin} + I_{OUTmax} ( R_L + R_K ) \quad [4]$$

This ultimately means that the current signal is not influenced by the hardware configuration in the output circuit. All that must be ensured is that the supply voltage is large enough.

## Features of two-wire signal transmission

**Simple handling:** provided that the current consumption of the transmitter and connected load are constant, the load and signal current can be transmitted on the same line. Only a load resistor is needed as a load; it must also be ensured that the operating voltage is sufficiently large to absorb any voltage drops which may occur in the power circuit. The voltage drop across the load resistor or the current through this resistor acts as the useful signal which in AMS 4712 is proportional to the applied pressure.



# AMS 4712 – two-wire current loop with the example of a 4 - 20 mA pressure transmitter

**Interference immunity:** thanks to the low-impedance receiver input on the one hand and the current source with a floating mass on the other (parallel switching of the real current source output resistor and the receiver input resistor), as opposed to voltage transmission the transmitted current signals are virtually unaffected by electromagnetic interference.

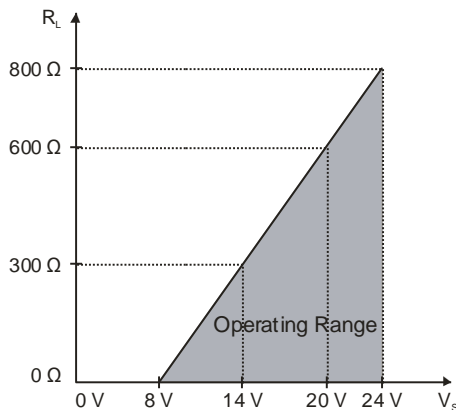

**Figure 5:** Area of load resistor  $R_L$  dependent on supply voltage  $V_S$ .

If an electromagnetic interference is to be expected (from welding systems, pumps, generators, other transmitters, etc.) or if long cables are in use, the current loop is the most suitable and cost-effective mean of transmitting information.

**Large transmission distances:** the transmission distance is dependent on the driver capability of the transmitter stage, the line resistances and the measuring resistor at the receiver end. If measurement and registering devices are built into the line, the load must be accounted for in relation to the input resistances of these measurement and registering devices.

If the voltage drop in the feed cables (line resistance) is factored into the voltage supply, the current signal is independent of the length of the line.

**Resolution:** as the sensing element signal is analog and the output should also be analog, signals may possibly be conditioned using a completely analog circuit. In this case the signal resolution is only determined by the amount of noise. A digital signal conditioning unit with an ADC would not be suitable for fast pressure changes due to the current consumption (4 mA).

**Error detection:** the advantage of 4 – 20 mA signal transmission is not just its immunity to interference but also the fact that a conclusive system of error detection is automatically included. On calibrated systems (the smallest input signal at the transmitter end  $I = 4$  mA at the output) signals of between  $> 0$  and  $< 4$  mA indicate an error in the system.  $I = 0$  mA signals a fractured wire in the power supply or a full functional failure. Signals of more than 20 mA suggest the presence of overvoltage at the input.

**Low system costs:** in place of a processor and a suitable driver for digital signal transmission over long distances, all that is needed for a two-wire current loop are a cable, resistor and measuring device.

**Perspective:** As long as signals have to be transmitted over long distances and in environments which are subject to interference and until wireless transmission through clouds has become standard, the proven system of two-wire transmission will continue to exist.



# AMS 4712 – two-wire current loop with the example of a 4 - 20 mA pressure transmitter

## Description of pressure transmitter AMS 4712

The compact pressure transmitters in the AMS 4712 series are high-precision, ready-to-use pressure sensors with a current output of 4 – 20 mA. They primarily consist of a silicon sensing element, signal conditioning ASIC and a voltage regulator.

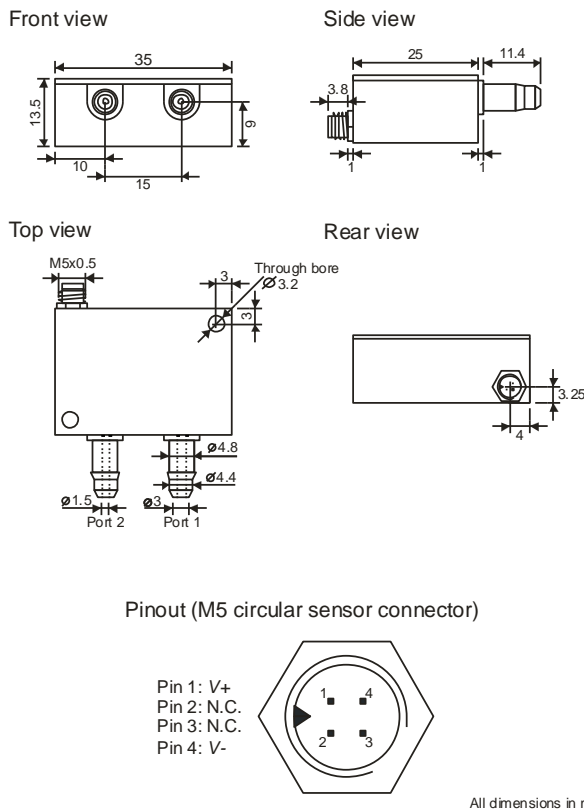

**Figure 6:** dimensions of transmitter AMS 4712

absolute or differential/relative measurements. There is also a bidirectional, differential version\* supplied in the  $\pm 5$ ,  $\pm 10$ ,  $\pm 20$ ,  $\pm 50$ , and  $\pm 100$  mbar ranges. This allows negative and positive pressures to be measured. Finally, barometric pressure can be measured with an optimized dynamics range using the 700 – 1,200 mbar variant.

All AMS 4712 have underside pressurization as a standard [2] and are thus suitable for measuring pressure with one-sided media application in several different liquids and reactive gases, in particular for level sensing. Compared to transmitters with oil seals

AMS 4712 can also be used to measure levels with a low fill height (from 50 cm).

Its dimensions of 35 x 25 x 13.5 mm<sup>3</sup> deserve a particular mention. The sensors comply with IP Code IP 67 and are suitable for external installation.

\*On the bidirectional, differential AMS 4712 sensor output current  $I_{OUT} = 12 \pm 8$  mA instead of  $I_{OUT} = 4 - 20$  mA. At  $\Delta P = 0$ ,  $I_{out} = 12$  mA.

In the sensing element the pressure on the silicon membrane is converted into an electrical, differential signal which is largely proportional to the applied pressure. In the ASIC a digital signal is generated from the analog signal of the sensing element, which is electrically calibrated, linearized and compensated for. The calibrated digital signal is converted in a DA converter and then supplied as an output signal by the voltage-controlled current source.

The sensors are calibrated, compensated for within the industrial temperature range of  $-25 - +85^{\circ}\text{C}$  and linearized. Supply voltage  $V_S$  can range from 8 – 36 V.

AMS 4712 is ready for operation without the need for any other components and is provided in a robust plastic package. In both its differential and relative versions, it has two side hose connections, with just one connector on the absolute model. Electrical connection is through a miniature M5 sensor plug.

Transmitter AMS 4712 is available in pressure ranges of 0 – 5 mbar to 0 – 2,000 mbar for differential/relative measurements and in ranges of 0 – 1 bar and 0 – 2 bar for



# AMS 4712 – two-wire current loop with the example of a 4 - 20 mA pressure transmitter

## Summary

Thanks to its analog signal transmission, with its two-wire current loop AMS 4712 is suitable for applications in an industrial environment. It is used where long transmission distances are required and where strong electromagnetic interference must be reckoned with. It comes ready for use and is available in many versions for a variety of applications, such as filter monitoring, level sensing, altitude measurement and much more.

## Further information

- [1] Product information AMS 4712: <https://www.amsys-sensor.com/products/pressure-sensor/ams4712-analog-pressure-transmitter-4-20ma-output/>
- [2] Application note underside pressurization AMS 4712: <https://www.amsys-sensor.com/downloads/notes/ams4711-media-compatible-pressure-transmitter-for-industrial-applications-in-matchbox-format-amsys-515e.pdf>

## Contact

AMSYS GmbH & Co. KG  
An der Fahrt 4  
55124 Mainz  
GERMANY

phone: +49 (0) 6131/469 875 0  
fax: +49 (0) 6131/469 875 66  
email: [info@amsys-sensor.com](mailto:info@amsys-sensor.com)  
internet: <https://www.amsys-sensor.com>