

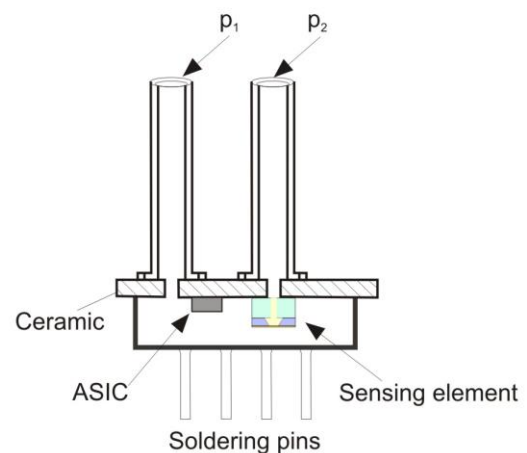

# AMS 5812 - OEM pressure sensor with analog and digital output

*Digital signal conditioning is becoming increasingly common in sensor technology. However, some sensor system states can be monitored more easily using analog values. For redundancy and system safety reasons it is sometimes advantageous if a sensor can provide both options.*

*Taking the piezoresistive OEM pressure sensor AMS 5812 as an example, the following application note describes the combination of an analog and digital output and explains the sensor's use in various applications.*

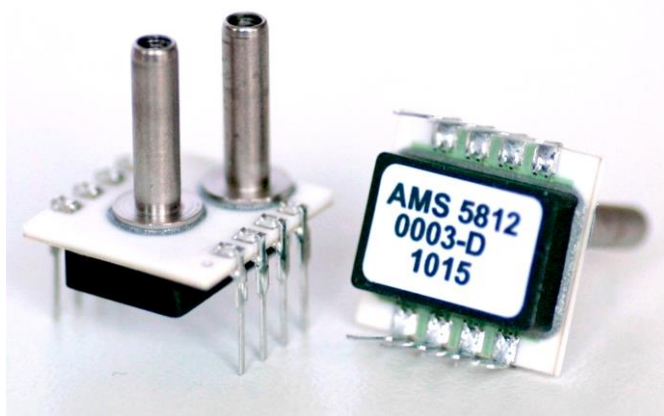

**Figure 1:** top view and schematic section of the AMS 5812 pressure sensor (for comparison: the ceramic substrate measures 15.2 x 9.4 mm<sup>2</sup>)

## Description of AMS 5812

The AMS 5812 [1] series consists of OEM pressure sensors which permit the measurement of absolute, relative and differential pressure and bidirectional differential pressure (positive and negative pressure). The sensors of the AMS 5812 series are individually calibrated and compensated for a temperature range of -25 to 85 °C during production. High precision as well as long-term stability are the result of high-quality piezoresistive pressure sensing elements combined with integrated signal processing and stored calibration values.

AMS 5812's distinguishing features are two independent outputs, an analog ratiometric voltage output with 0.5...4.5 V (or 2.5 V ± 2 V for the bidirectional differential version) and an I<sup>2</sup>C bus interface.

The sensors are available for pressure ranges from 0...0.075 PSI up to 100 PSI but can also be calibrated to suit specific customer requirements.

A ceramic substrate with dual inline soldering connections and a ceramic housing give the pressure sensor high mechanical stability.



# AMS 5812 – Ratiometry in pressure sensors

## Theory of operation

The pressure measurement takes place at AMS 5812's piezoresistive silicon pressure sensing element. Here, the pressure applied to the pressure sensing element is converted into a differential, analog voltage signal which is almost proportional to the applied pressure. Then this voltage signal is amplified by the CMOS-ASIC (see *Figure 2*) and transmitted to the ADC, where it is converted into a digital value. The ADC's resolution is 14 bits. In order to obtain standardized output values, the digitized signals are electronically calibrated, temperature compensated and linearized in the microprocessor ( $\mu$ P) block.

During calibration correction coefficients are determined at various pressures for each individual sensor and stored in the specific sensor's EEPROM. The temperature signal required for temperature compensation is measured at the piezoresistive pressure sensing element (direct media contact) at various temperatures and converted into a digital value. The cyclic program running in the ASIC's microprocessor block computes the corrected and normalized, digital pressure signal based on the respective pressure and temperature values with the help of the correction coefficients. These corrected digital pressure and temperature values are written to the ASIC's output register and updated cyclically (typically every 0.5 ms at a 14 bit ADC resolution). Both, the pressure and temperature value are available as digital data, while the pressure value is also converted into an analog voltage signal by a DAC (11 bit) and available for analog readout.

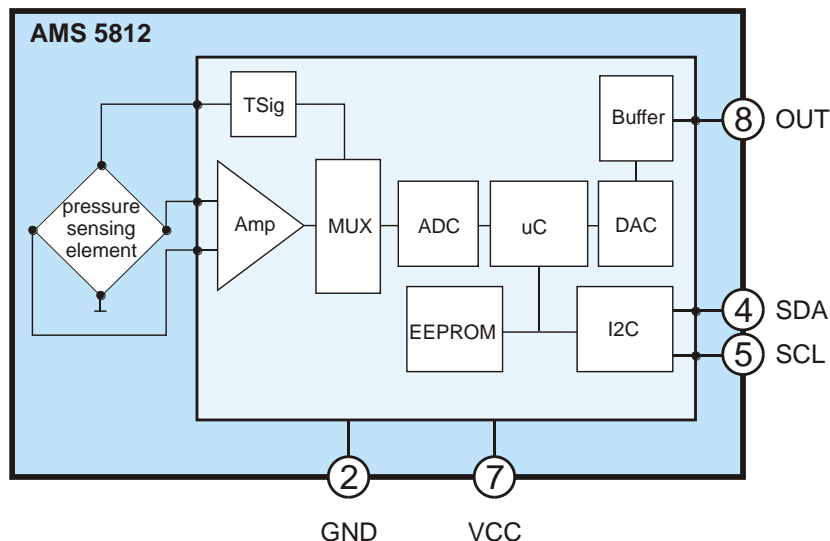

**Figure 2:** schematic circuit diagram of AMS 5812



# AMS 5812 – Ratiometry in pressure sensors

## Ratiometric analog output signal

In the first approximation the following equation applies to the output voltage of piezoresistive sensing elements like those used in AMS 5812:

$$V_{OUT} = S \cdot p \cdot V_S \text{ where}$$

$S$  = sensitivity,

$p$  = applied pressure and

$V_S$  = supply voltage

It can easily be seen that a piezoresistive silicon sensing element's output signal  $V_{out}$  is directly proportional to the supply voltage  $V_S$ . This means that the sensing element's signal changes synchronously to the change in the supply voltage: an effect which is called "ratiometricity" [2].

For example, if the supply voltage  $V_S$  changes by  $\pm 5\%$  the sensing element's output signal  $V_{out}$  will change by the same ratio. That is the reason to use normally a stabilized voltage source.

Assuming that nowadays a microprocessor is used for signal conditioning in most sensors (as in AMS 5812), an analog-digital converter (ADC) is inevitably required for signal conditioning. This part of the signal conditioning system digitizes the sensing element's analog output signal in relation to its external reference voltage  $V_{Ref}$ . At the same analog input value and identical resolution but with a smaller reference voltage the converted digital value increases and vice versa.

Taking both the sensing element and the AD converter into account the digitized value will depend on the pressure, resolution and ratio of the sensing element's signal to the reference voltage.

If the sensing element's supply voltage  $V_S$  and the ADC's reference voltage  $V_{Ref}$  change synchronically ( $V_S = V_{Ref}$ ), the ratio of the sensing element's signal to the reference voltage remains constant at a constant pressure ( $p = \text{constant}$ ) than the digital output signal is independent from the change in supply voltage  $V_S$ . Therefore, the signal is non-ratiometric and only changes if the pressure value changes the digital signal.

If we only take the analog output of the AMS 5812 into account, the digital signal must be converted by a DA converter (Figure 3). The converter's reference voltage also plays an important role here as the DAC converts the digital signal into an analog signal in relation to its reference voltage  $V_{Ref}$ . At the same digital input value and resolution but with smaller reference voltage of the

DAC the analog output decreases and the signal increases if the reference voltage increases too.

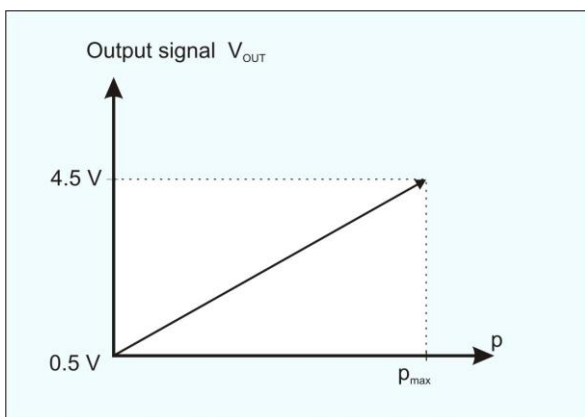

**Figure 3:** calibrated analog output signal AMS 5812

As described above the digital signal generated by the ADC and processed by the microcontroller is non-ratiometric to the supply voltage, but if the DAC's reference voltage  $V_{Ref}$  decreases by 5 % its output voltage will also decrease by 5 %. Thus, if the supply voltage  $V_S = V_{Ref}$  changes by a certain amount, this change causes a synchronous fluctuation in the sensing element's output signal and in the converted analog output signal. Therefore AMS 5812's analog output voltage is ratiometric like the sensing element's signal and the digital signal not.



# AMS 5812 – Ratiometry in pressure sensors

## I<sup>2</sup>C interface

In addition to the analog voltage output the pressure sensors in the AMS 5812 series have a digital output (I<sup>2</sup>C interface). Using this interface, the respective current and corrected digital pressure and temperature values can be read from the sensor's output register.

The serial I<sup>2</sup>C data bus has been an industrial standard for many years. As the AMS 5812 is an OEM component, which is installed by the customer in the respective system at the place of measurement, it was logical to select this easy to use interface which is especially suitable for short transmission distances.

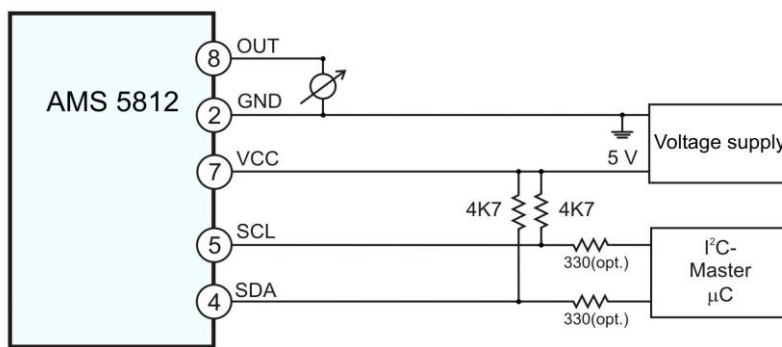

Communication through the I<sup>2</sup>C bus operates on a master/slave principle, where a data transfer is always initiated by a master (e.g. an external microprocessor), which activates the sensors. These operate as slaves and respond on request according to a given protocol.

**Figure 4:** circuit for digital signal transmission on the AMS 5812 [1]

Two bus lines are needed for communication through the I<sup>2</sup>C interface: a serial data line (SDA) and a serial clock line (SCL). SDA and SCL are bidirectional lines, which are connected to the positive supply voltage by pull-up resistors (recommendation: R = 4.7 kΩ, see [1]).

Communication is made according to the usual I<sup>2</sup>C protocol. All AMS 5812 devices have the 7-bit slave address 0x78hex (1111000b, factory setting).

If several AMS 5812s are connected to the same I<sup>2</sup>C bus, each sensor must be programmed with its own, separate address. On request each sensor can be configured with a second 7-bit address at the factory. Alternatively, the customer can program his own I<sup>2</sup>C addresses using the starter kit [3]. AMS 5812 devices programmed in this way will respond to both addresses then, the standard address 0x78hex and the additional custom address. In this way a sensor network with a maximum of 127 addresses can be created (see Figure 5).

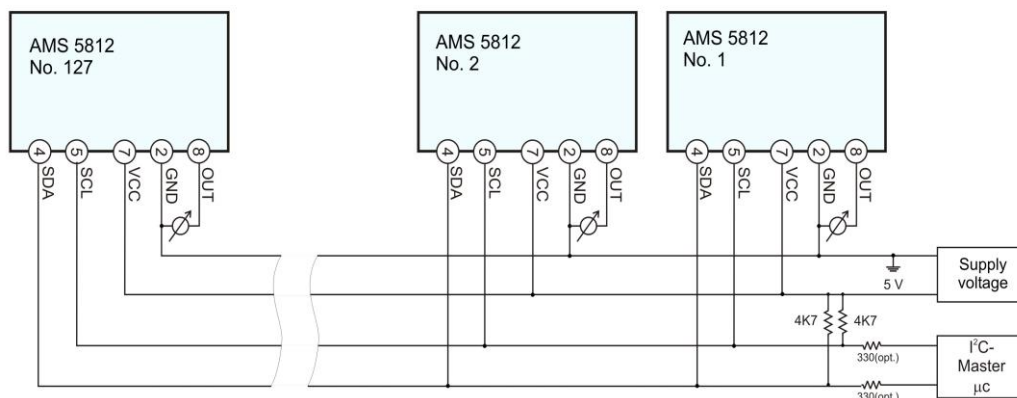

**Figure 5:** network with several AMS 5812 devices



# AMS 5812 – Ratiometry in pressure sensors

## AMS 5812 – sensors with an analog and digital output

AMS 5812 allows the usage of the analog and digital outputs independently from one another. These outputs differ in the following aspects: The analog signal has a resolution of 11 bit and only allows the pressure value's readout. In contrast the digital signal has a resolution of 14 bit and allows the pressure and temperature value's readout. Furthermore, the analog signal is ratiometric to the supply voltage; while the digital value is not ratiometric.

The combination of both functions permits several interesting and safety-relevant applications. For example:

- Analog local pressure control (with an indicating instrument) and digital signal conditioning
- Online error detection when analog values are beyond the valid output voltage range
- Digital signal conditioning for local system control and remote transmission of the analog output signal
- Configuration assistance for system parameters using the analog display

## Digital signal conditioning and analog pressure control

If a digital pressure sensor signal is processed by a downstream electronic system (e.g. control of a pump system), it is not possible to monitor the correct function of the entire system directly without some difficulty. In case of a fault or failure of the sensor or another function group in the system, there is no way of knowing what caused the problem. In such an electronic system the digital signal processing might be checked using plausibility routines after recording the measurements and digitizing them. But it is not possible to draw direct conclusions on the sensing element's behavior using the downstream amplifier circuitry. With AMS 5812 it is possible to check if the measurement is working correctly using the analog output signal (e.g. 0.5... 4.5 V) and a voltmeter if the applied pressure is known. Therefore, the complete system can be monitored using plausibility routines and the analog voltage output data.

## Online error detection (sensing element behavior) when analog values are beyond the valid output voltage range

Assuming AMS 5812's calibration is correct the analog output signal on AMS 5812 (except for bidirectional sensors) has an offset of 0.5 V. This means, that if the analog output voltage is smaller than 0.5 V at nominal zero pressure an error occurred. If the analog voltage output is 0 V there is no sensing element signal or the ASIC is not working; this can be verified by checking the digital section of the setup. If the analog output voltage is larger than 4.5 V, it must be assumed that the sensing element is broken.

## Digital signal conditioning for local system control and analog remote transmission of the pressure signal

If the digitized pressure signal is used in a production system for local system control, for example, and if the entire system is monitored from the process control center for safety reasons, the control functions must be led to the control center. As sensor-dependent processes always center on the digital processing of the converted analog sensing element signal, the measurement and measurement data processing must be controlled independently from each other.



# AMS 5812 – Ratiometry in pressure sensors

If the processes take place in a harsh industrial environment, care must be taken to provide error-free signal transmission. In this case the analog voltage signal could be transmitted error free to the control center along a two- or three-wire current line. For this purpose, a voltage-to-current converter (e.g. AM462 from Analog Microelectronics [4]) has to be used to convert AMS 5812's analog output voltage signal into a standardized 4 (0)–20 mA signal, which can be transmitted across distances of almost any length. (In two-wire operation the sensor's and AM462's current consumption must not exceed 4 mA).

The correct measurement data processing must be monitored by checking the system parameters afterwards.

## Configuration assistance for system parameters using the analog display

If a more complex system, consisting of the sensor, a digital controller and various actuators, for example, must be set up and the system's function must be verified, the analog voltage output can prove useful. Users can immediately see which pressure is applied and can set the parameters depending on the pressure. If the pressure varies, the pressure-dependent functions of the system can be monitored directly. See also AMS 5105, analog OEM sensor with 2 individual switching outputs [5].

## Summary

AMS 5812 is a OEM pressure sensor which features a ratiometric analog output and a non-ratiometric digital I<sup>2</sup>C interface output. In addition to the pressure values the temperature at the pressure sensing element can be recorded and read out digitally. The sensor comes ready to install and does not need any additional components.

The series is available for the following pressure ranges:

- **Lowest pressure ranges** differential and bidirectionally differential: 0-0.075; 0-0.15 psi / ± 0.075; 0.15 psi
- **Low pressure ranges** differential and bidirectionally differential: 0-0.3; 0-0.8; 0-1.5 psi / ± 0.3; ± 0.8; ± 1.5 psi
- **Standard pressure ranges** differential and bidirectionally differential: 0-3; 0-5; 0-15; 0-30; 0-60; 0-100 psi / ± 3; ± 5; ± 15 psi
- **Absolute pressure ranges:** 0-15 psi and 0-30 psi, barometric: 11-17.5 psi





# AMS 5812 – Ratiometry in pressure sensors

## Further information

- [1] Product information AMS 5812: <https://www.amsys-sensor.com/products/pressure-sensor/ams5812-pressure-sensor-with-analog-and-digital-output/>
- [2] What is ratiometry?: <https://www.amsys-sensor.com/downloads/notes/ams5812-ratiometry-in-pressure-sensors-amsys-521e.pdf>
- [3] Starter kit AMS 5812: <https://www.amsys-sensor.com/products/accessory/starter-kit-for-pressure-sensors-ams-5812/>
- [4] Datasheet AM462: <https://www.analog-micro.com/en/products/ics/uiconverter/am462/>
- [5] Product information AMS 5105: <https://www.amsys-sensor.com/products/pressure-sensor/ams5105-pressure-sensor-with-switching-output/>

## Contact

AMSYS GmbH & Co. KG  
An der Fahrt 4  
55124 Mainz  
GERMANY

phone: +49 (0) 6131/469 875 0  
fax: +49 (0) 6131/469 875 66  
email: [info@amsys-sensor.com](mailto:info@amsys-sensor.com)  
internet: <https://www.amsys-sensor.com>